

**APPENDIX M CONDUCTIVITY SYSTEM FREQUENCY RESPONSE
CALCULATIONS AND TESTS**

Appendix M Conductivity System Frequency Response Calculations and Test

newfltr0.mcd

The following analysis calculates the total conductivity system frequency response. The only stage with op amp compensation circuits is the Conductivity Buffer Amplifier at the output of the absolute value circuit.

The frequency compensation associated with the absolute value circuit and its attendant output buffer is calculated as follows:

The absolute value circuit is a unity gain circuit with a very low value of capacitance in the feedback circuit. It is followed up by a buffer amplifier with a 100 pf compensation capacitor. First, from measurements made on the bread board, the gain of the rectifier/buffer stage is -5.14 at a frequency of .2 Hz. Working backwards from the gain formula for the inverting amplifier, compute the equivalent value of input resistance that is represented by the active rectifier:

Rfr = feedback resistor in the rectifier/buffer amplifier

Rir = the input resistance represented by the ac rectifier

Avr = dc gain of the rectifier/buffer stage

Rfrr(f) = frequency dependent feedback resistance in the rectifier/buffer amplifier

Avrr(f) = frequency dependent gain of the rectifier/buffer stage

The fast A/D converter samples at 2000 Hz so the frequency response analysis is run from 2 to 2000 Hz.

Let f be a range from 2 Hz to 2000 Hz: $f := 2, 4 .. 2000$

$$Rfr := 200000 \quad Avr := -5.14 \quad Cr := .00010 \cdot 10^{-6} \quad Rir := \frac{-Rfr}{Avr}$$

$$Rir = 3.891 \cdot 10^4 \quad Rfrr(f) := \frac{\frac{1}{2 \cdot \pi \cdot f \cdot Cr} \cdot Rfr}{Rfr + \frac{1}{2 \cdot \pi \cdot f \cdot Cr}}$$

$$Avrr(f) := \frac{-Rfrr(f)}{Rir} \quad Rectfltr(f) := \frac{Avrr(f)}{-1 \cdot \left(\frac{Rfr}{Rir} \right)}$$

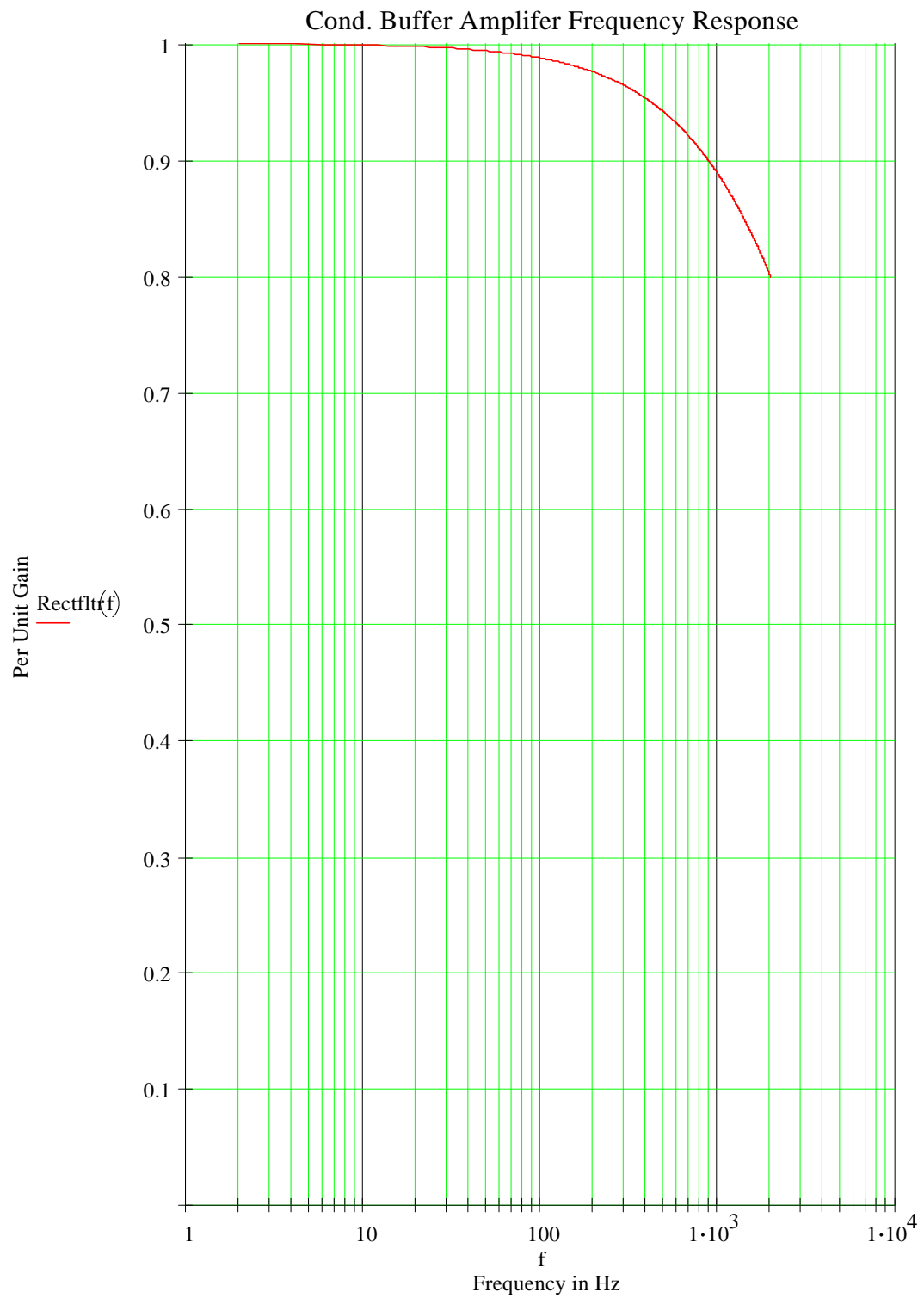

Figure M.1 Frequency Response of Absolute Value Circuit / Conductivity Buffer Amplifier

The conductivity buffer amplifier above is the only frequency susceptible stage significantly affecting the output of the Conductivity Electronics Circuit Board in the frequency range from 2 to 2000 Hz..

$$\text{Condbd}(f) := \text{Rectfltr}(f)$$

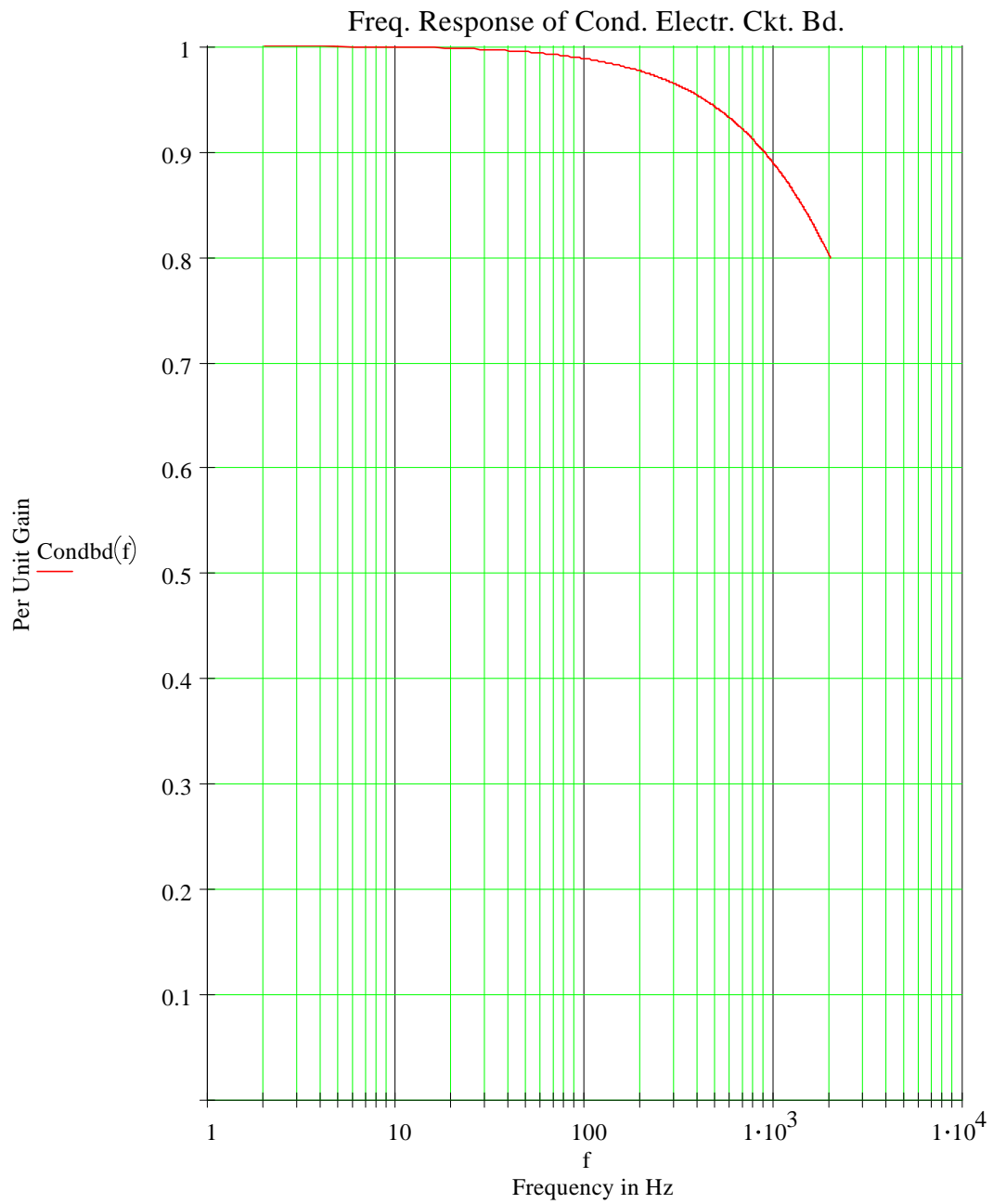

Figure M.2 Frequency Response of the Conductivity Electronics Circuit Board

Next the effect of the Filter Circuit Board is calculated:

The conductivity signal is passed from the conductivity buffer amplifier on the Conductivity Electronics Circuit Board through the Analog Mother Board (where no signal processing takes place) to one of the filter channels on the Filter Electronics Circuit Board. On the Filter Electronics Circuit Board it is passed through a Filter Input Buffer Amplifier into an 8 Pole Butterworth Low Pass Filter and then through a Filter Output Buffer Amplifier. The Filter Input Buffer Amplifier is set to a gain of -6.99. At the output of the Filter Output Buffer Amplifier the signal is split. One Part is presented to the input of the Differentiator Stage while the other part is routed off the Filter Electronics Circuit Board to a fast A/D converter channel. The following is an analysis of the frequency response of these electronics.

The Buffer frequency compensation components are as follows:

Rf1 is the value of the feedback resistor for the Filter Input Buffer.

Rf2 is the value of the feedback resistor for the Filter Output Buffer.

Rf3 is the value of the feedback resistor for the Differentiator Output Buffer.

Rfb1(f) is the value of the freq dependent feedback impedance for the Filter Input Buffer.

Rfb2(f) is the value of the freq dependent feedback impedance for the Filter Output Buffer.

Rfb3(f) is the value of the freq dependent feedback impedance for the Differentiator Output Buffer.

Cf1 is the value of the compensation capacitor for the Filter Input Buffer.

Cf1 is the value of the compensation capacitor for the Filter Output Buffer.

Cf1 is the value of the compensation capacitor for the Differentiator Output Buffer.

Rif1 is the value of the inverting input resistor for the Filter Input Buffer.

Rif2 is the value of the inverting input resistor for the Filter Output Buffer.

Rif3 is the value of the inverting input resistor for the Differentiator Output Buffer.

f is the frequency applied to the gain stage.

Avf1(f) is the freq dependent voltage gain of the Filter Input Buffer Amplifier.

Avf2(f) is the freq dependent voltage gain of the Filter Output Buffer Amplifier.

Avf3(f) is the freq dependent voltage gain of the Differentiator Buffer.

The fast A/D converter samples at 2000 Hz so the frequency response analysis is run from 2 to 2000 Hz.

Let f be a range from 2 Hz to 2000 Hz: $f := 2, 4 \dots 2000$

For the Filter Input Buffer Amplifier:

$$Cf1 := 0.0001 \cdot 10^{-6} \quad Rif1 := 10000 \quad Rf1 := 69900$$

$$Rfb1(f) := \frac{\frac{1}{2 \cdot \pi \cdot f \cdot Cf1} \cdot Rf1}{Rf1 + \frac{1}{2 \cdot \pi \cdot f \cdot Cf1}} \quad Avf1(f) := -\frac{Rfb1(f)}{Rif1}$$

The effect of the Filter Input Buffer Amplifier will be calculated first:

To characterize the frequency response calculate a frequency dependent gain stage th multiplied times the input voltage at each frequency to determine the output. The dc of the circuit ($-Rf1/Rif1$) will be used as a reference.

$$Fltrout1(f) := \frac{Avf1(f)}{-1 \cdot \left(\frac{Rf1}{Rif1}\right)}$$

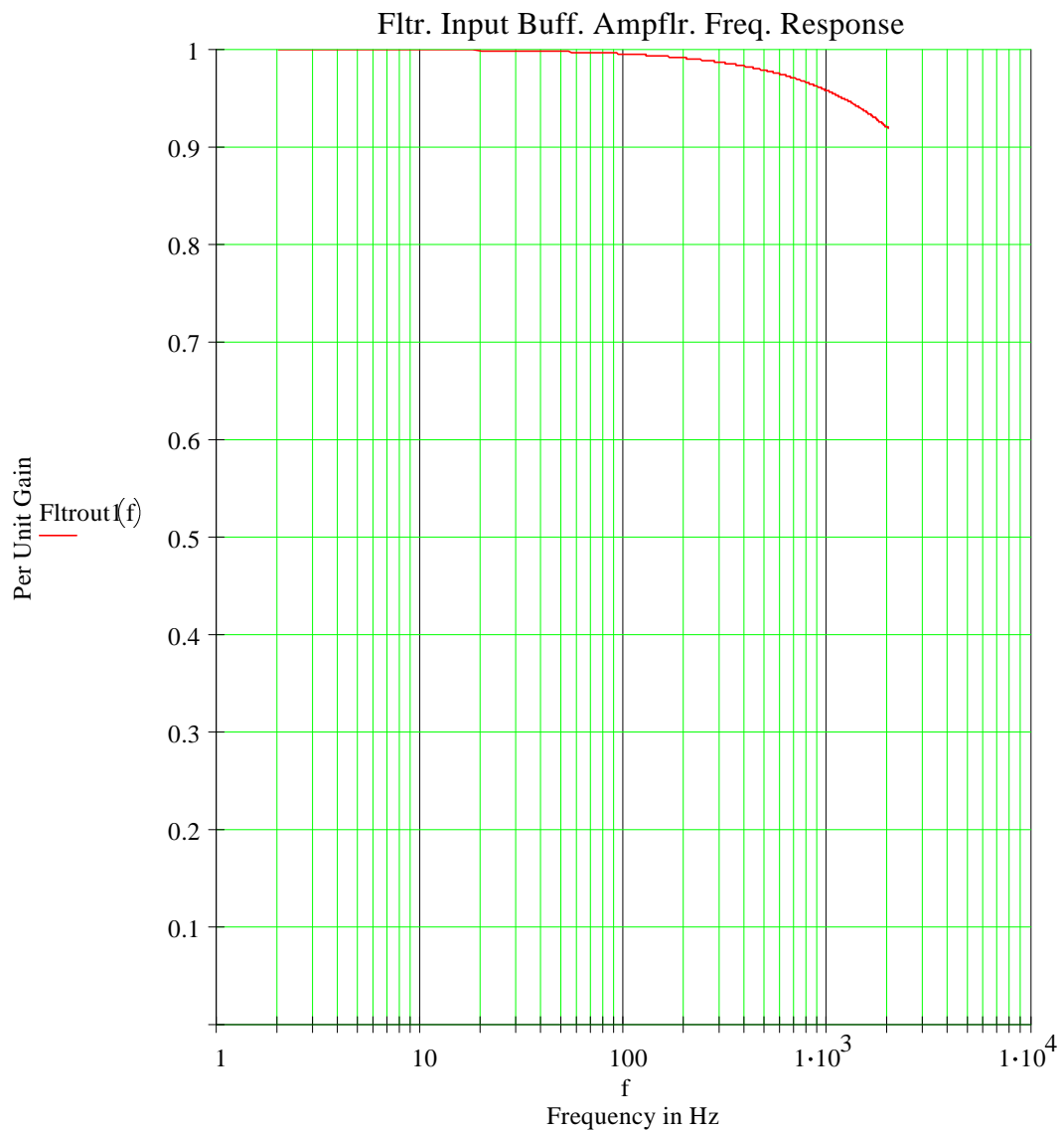

Figure M.3 Frequency Response Curve of Filter Input Buffer Amplifier

The frequency response of the Filter Output Buffer Amplifier is calculated next:

$$Cf2 := 0.0001 \cdot 10^{-6} \quad Rif2 := 10000 \quad Rf2 := 10000$$

$$Rfb2(f) := \frac{\frac{1}{2 \cdot \pi \cdot f \cdot Cf2} \cdot Rf2}{Rf2 + \frac{1}{2 \cdot \pi \cdot f \cdot Cf2}} \quad Avf2(f) := -\frac{Rfb2(f)}{Rif2}$$

To characterize the frequency response calculate a frequency dependent gain stage that multiplied times the input voltage at each frequency to determine the output. The dc gain of the circuit ($-Rf2/Rif2$) will be used as a reference.

$$Fltrout2(f) := \frac{Avf2(f)}{-1 \cdot \left(\frac{Rf2}{Rif2}\right)}$$

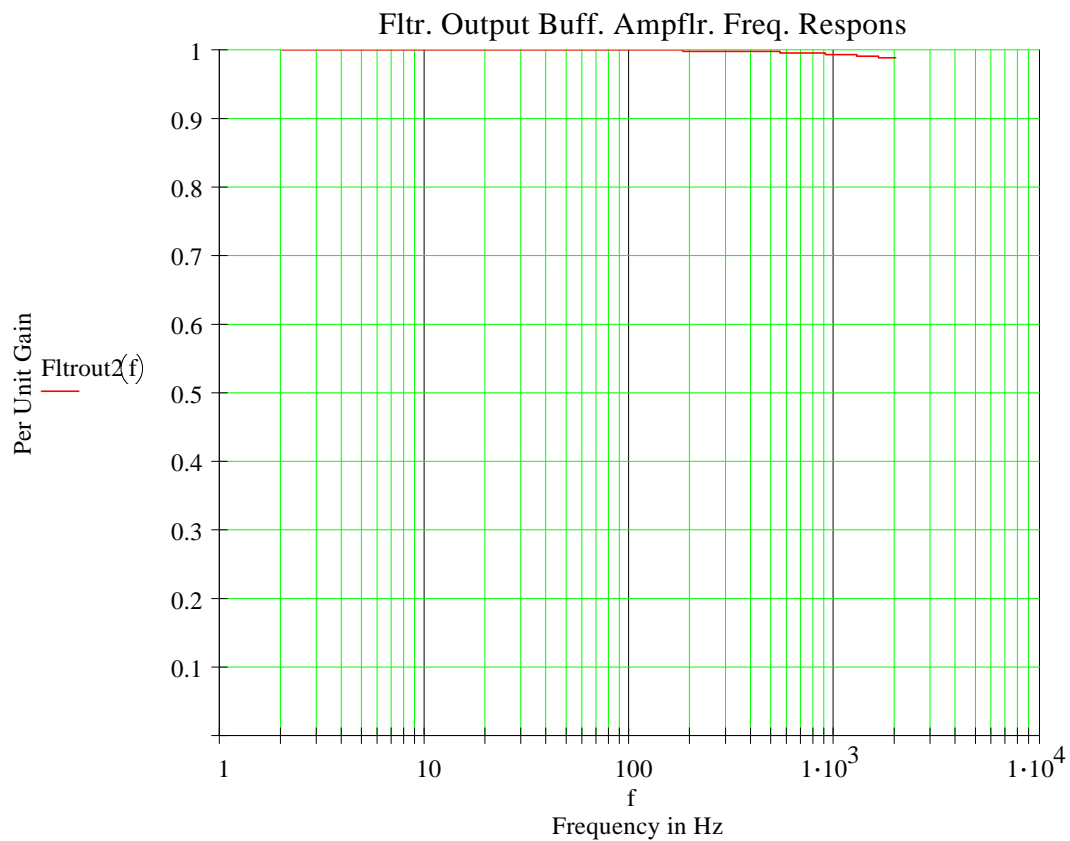

Figure M.4 Frequency Response Curve of Filter Output Buffer Amplifier

The Differentiator Output Buffer Amplifier will be the same as the Filter Output Buffer Amplifier because it uses the same component values.

$$\text{Fltrout3}(f) := \text{Fltrout2}(f)$$

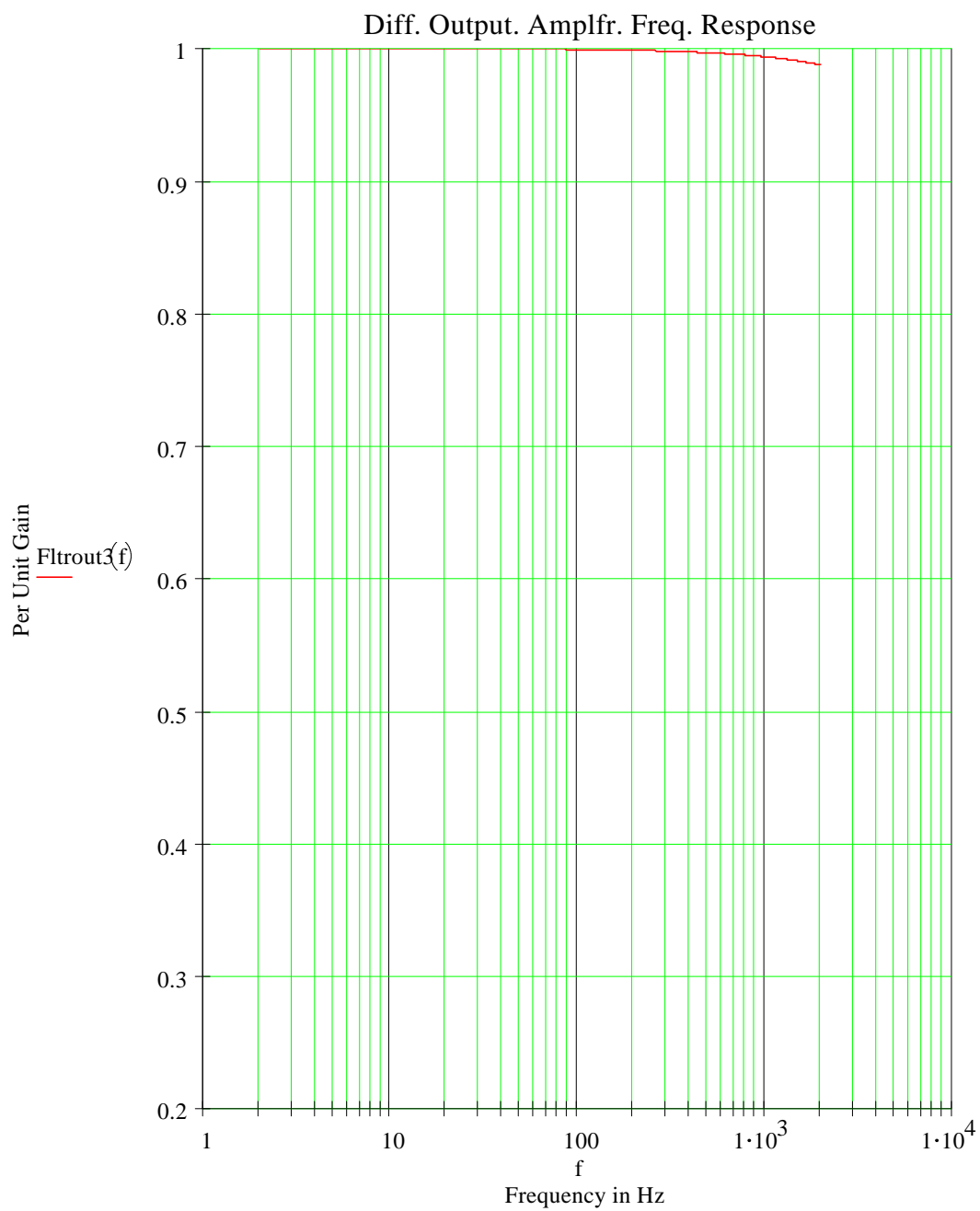

Figure M.5 Frequency Response of the Differentiator Output Buffer Amplifier

The effect of the 8 pole butterworth filter can calculated as follow
 fc = corner frequency

$$fc := 1000$$

$$Wp1(fc) := 2 \cdot \pi \cdot (1.000000) \cdot fc \quad Q1 := 0.509796$$

$$Wp2(fc) := 2 \cdot \pi \cdot (1.000000) \cdot fc \quad Q2 := 0.601345$$

$$Wp3(fc) := 2 \cdot \pi \cdot (1.000000) \cdot fc \quad Q3 := 0.899976$$

$$Wp4(fc) := 2 \cdot \pi \cdot (1.000000) \cdot fc \quad Q4 := 2.562915$$

$$\omega(f) := 2 \cdot \pi \cdot f$$

$$S(f) := j \cdot \omega(f)$$

$$\text{Term1}(fc) := Wp1(fc)^2 \cdot Wp2(fc)^2 \cdot Wp3(fc)^2 \cdot Wp4(fc)^2$$

$$\text{Term2}(S) := \left(S^2 + S \cdot \frac{Wp1(fc)}{Q1} + Wp1(fc)^2 \right)$$

$$\text{Term3}(S) := \left(S^2 + S \cdot \frac{Wp2(fc)}{Q2} + Wp2(fc)^2 \right)$$

$$\text{Term4}(S) := \left(S^2 + S \cdot \frac{Wp3(fc)}{Q3} + Wp3(fc)^2 \right)$$

$$\text{Term5}(S) := \left(S^2 + S \cdot \frac{Wp4(fc)}{Q4} + Wp4(fc)^2 \right)$$

$$H(S) := \frac{\text{Term1}(fc)}{\text{Term2}(S) \cdot \text{Term3}(S) \cdot \text{Term4}(S) \cdot \text{Term5}(S)}$$

$$H1(x) := \left[(\text{Im}(H(S(f))))^2 + (\text{Re}(H(S(f))))^2 \right]^{.5}$$

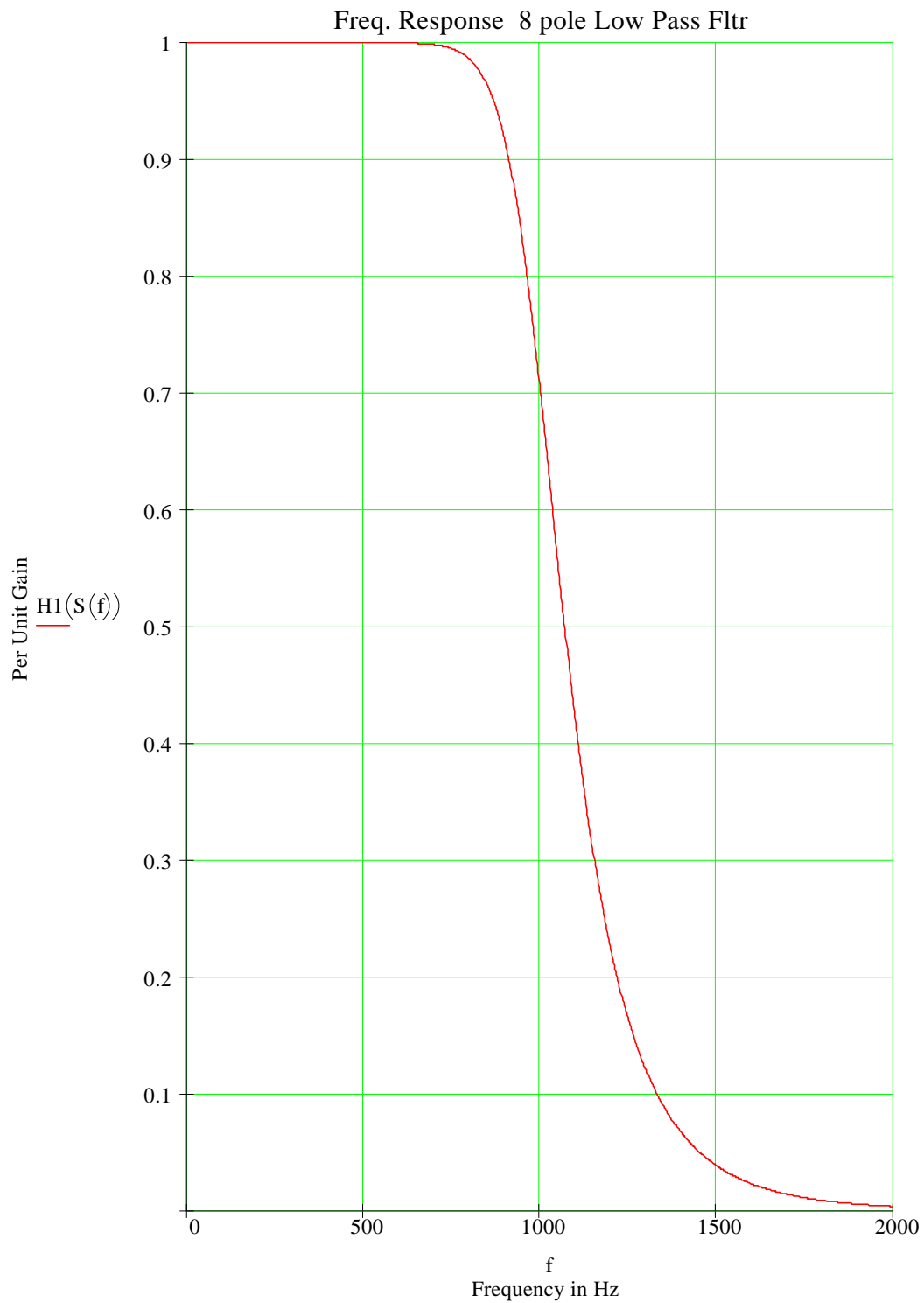

Figure M.6 Frequency Response of 1000 Hz, 8 pole, Low Pass, Butterworth Filter

The transfer function for the Filter Input Buffer Amplifier, the 8 Pole Butterworth Low Pass Filter with f_c at 1000 Hz, and the Filter Output Buffer Amplifier is calculated as follows::

$$\text{Fltrbdcondou}(f) := \text{Fltrout1}(f) \cdot \text{Fltrout2}(f) \cdot \text{H1}(S(f))$$

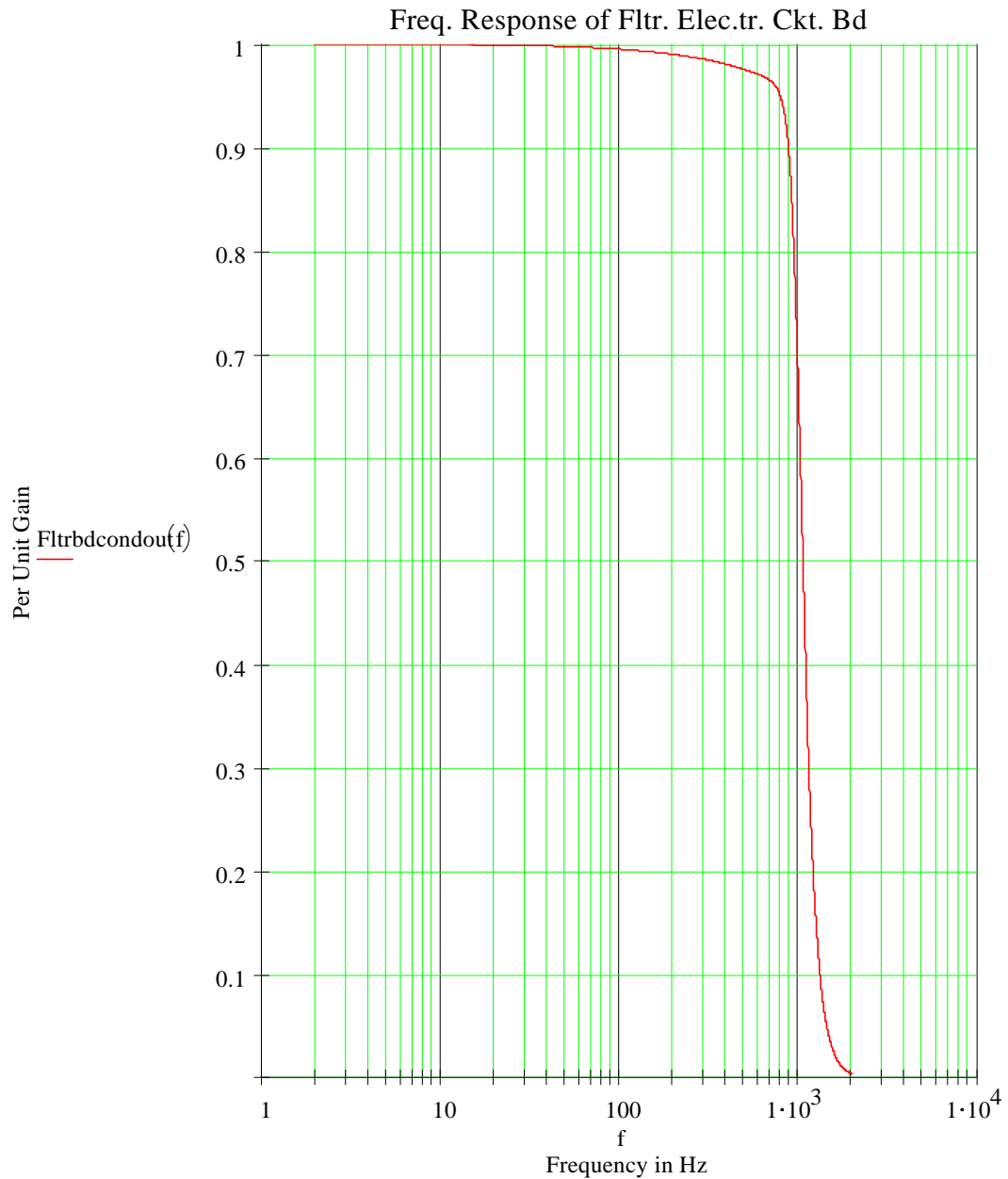

Figure M.7 Frequency Response Curve for Conductivity Filter Channel of Filter Electronics Circuit Board

The combined effects of frequency compensation and filtering on both the Conductivity Electronics Circuit Board and the Filter Circuit Board is calculated follows:

$$\text{TotCond}(f) := \text{Fltrbdcondou}(f) \cdot \text{Condbd}(f)$$

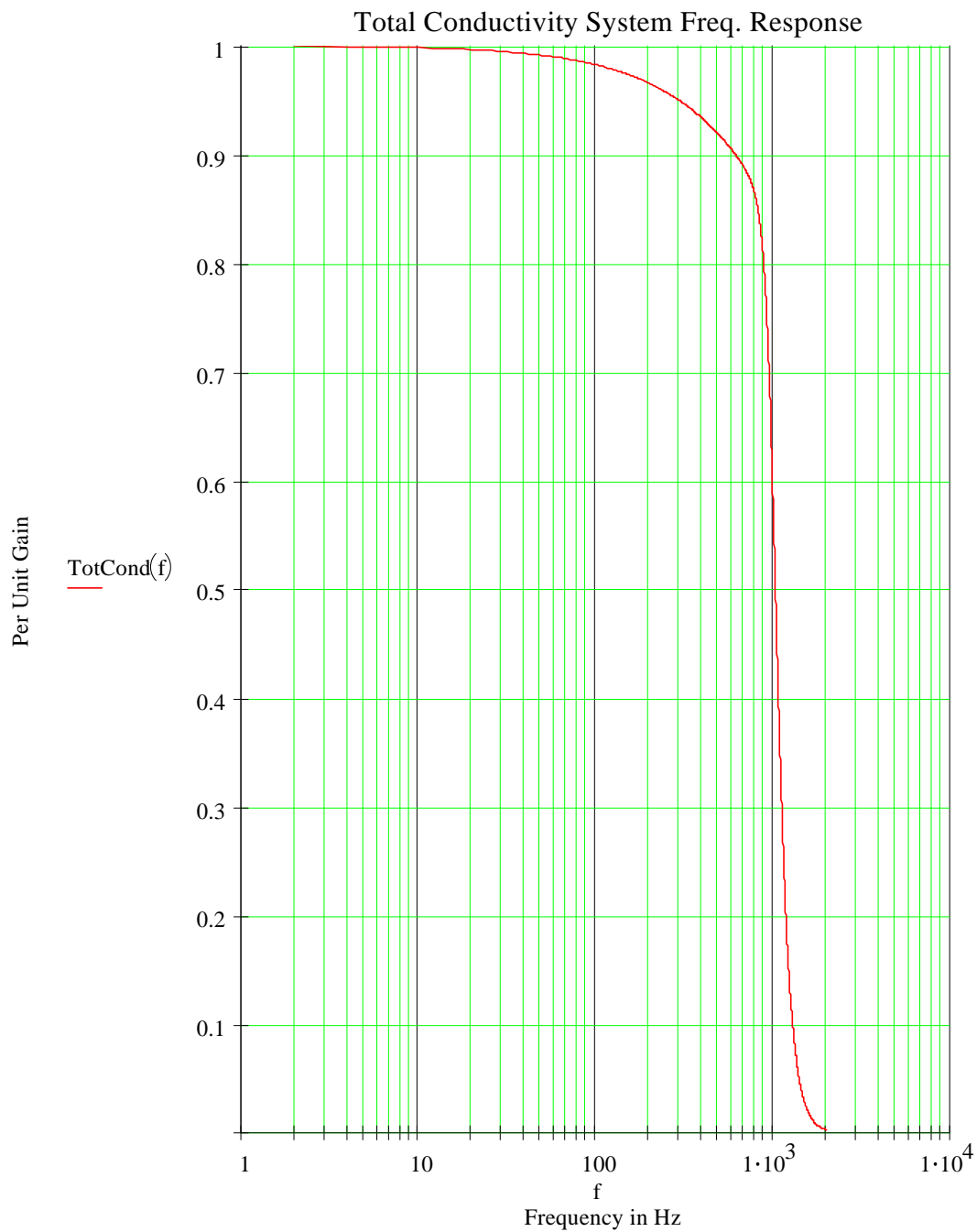

Figure M.8 Frequency Response of the Total Conductivity System

A correction term is calculated that can be multiplied times the output at a specific frequency in order to correct the frequency response.

$$\text{CondCorrection}(f) := \frac{1}{\text{TotCond}(f)}$$

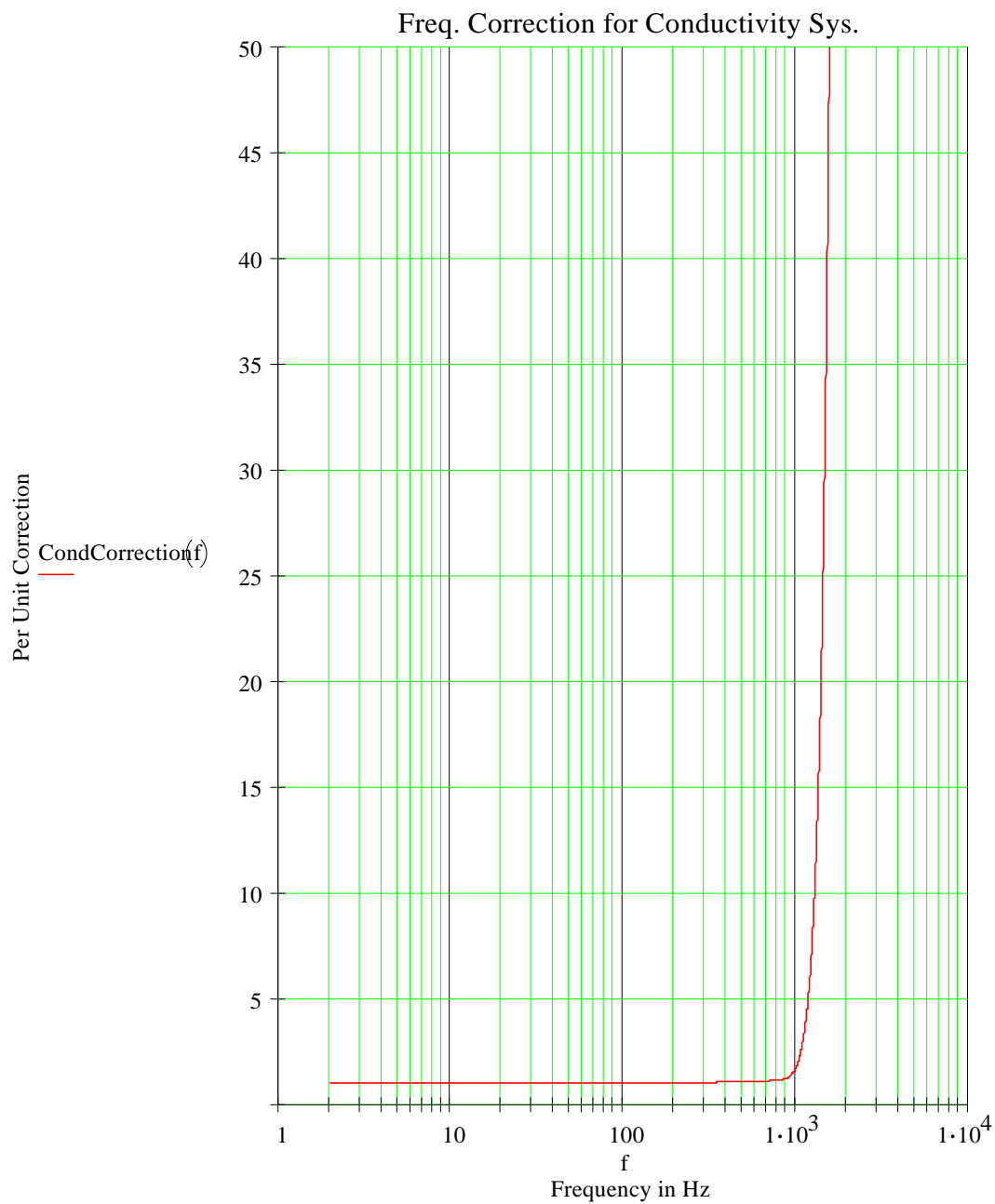

Figure M.9 Frequency Response Correction Curve for Total Conductivity System

Finally if we add the effect of the Differentiator Output Buffer Amplifier we can calculate the frequency response of the Total dC/dt circuit (without the effects of the actual differentiation).

$$\text{Diffcond}(f) := \text{TotCond}(f) \cdot \text{Fltrout3}(f)$$

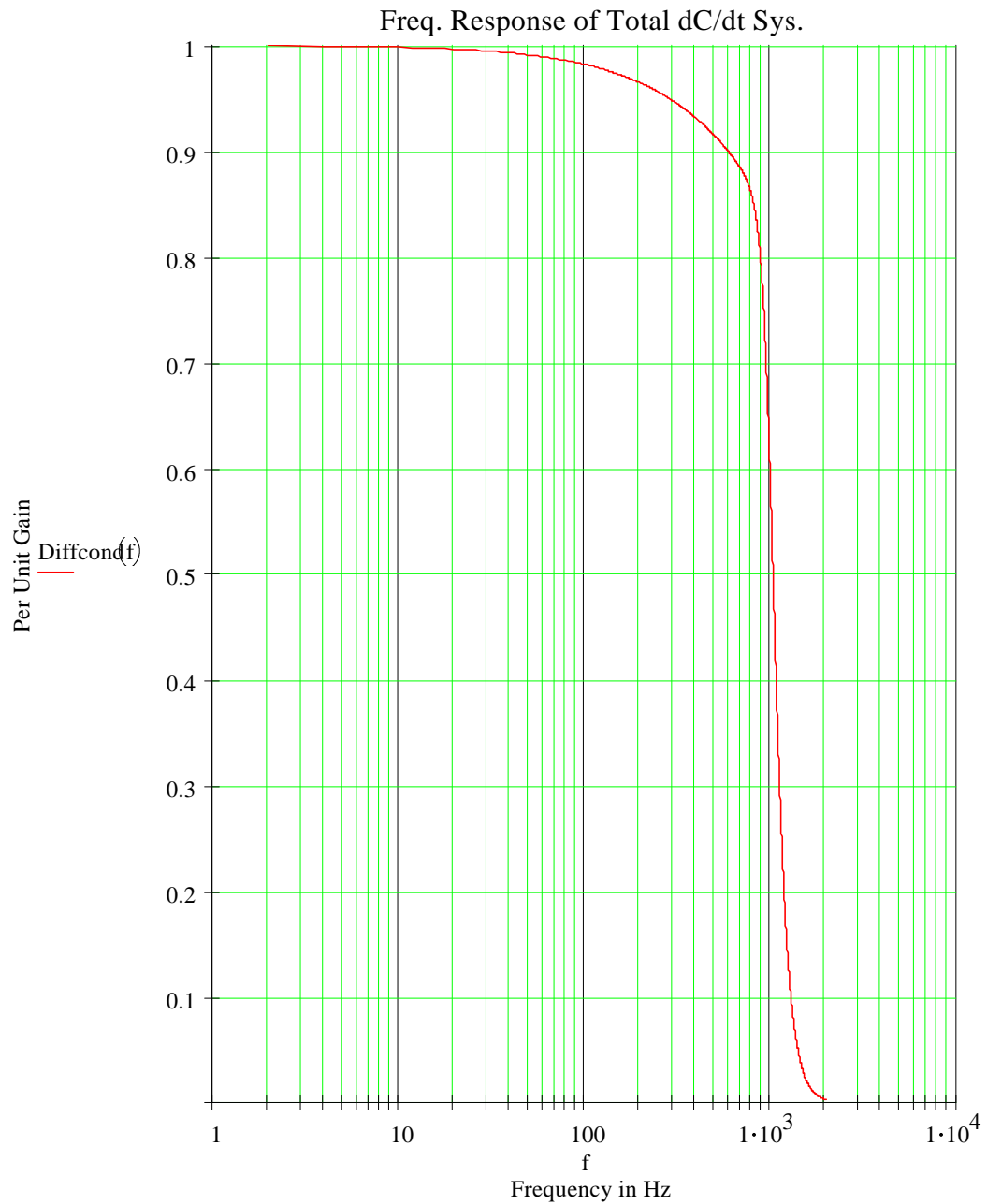

Figure M.10 Frequency Response of entire Conductivity Differentiator signal path

The frequency correction function to apply to the derivative conductivity data is calculated as follows:

$$\text{DiffcondCorrection}(f) := \frac{1}{\text{Diffcond}(f)}$$

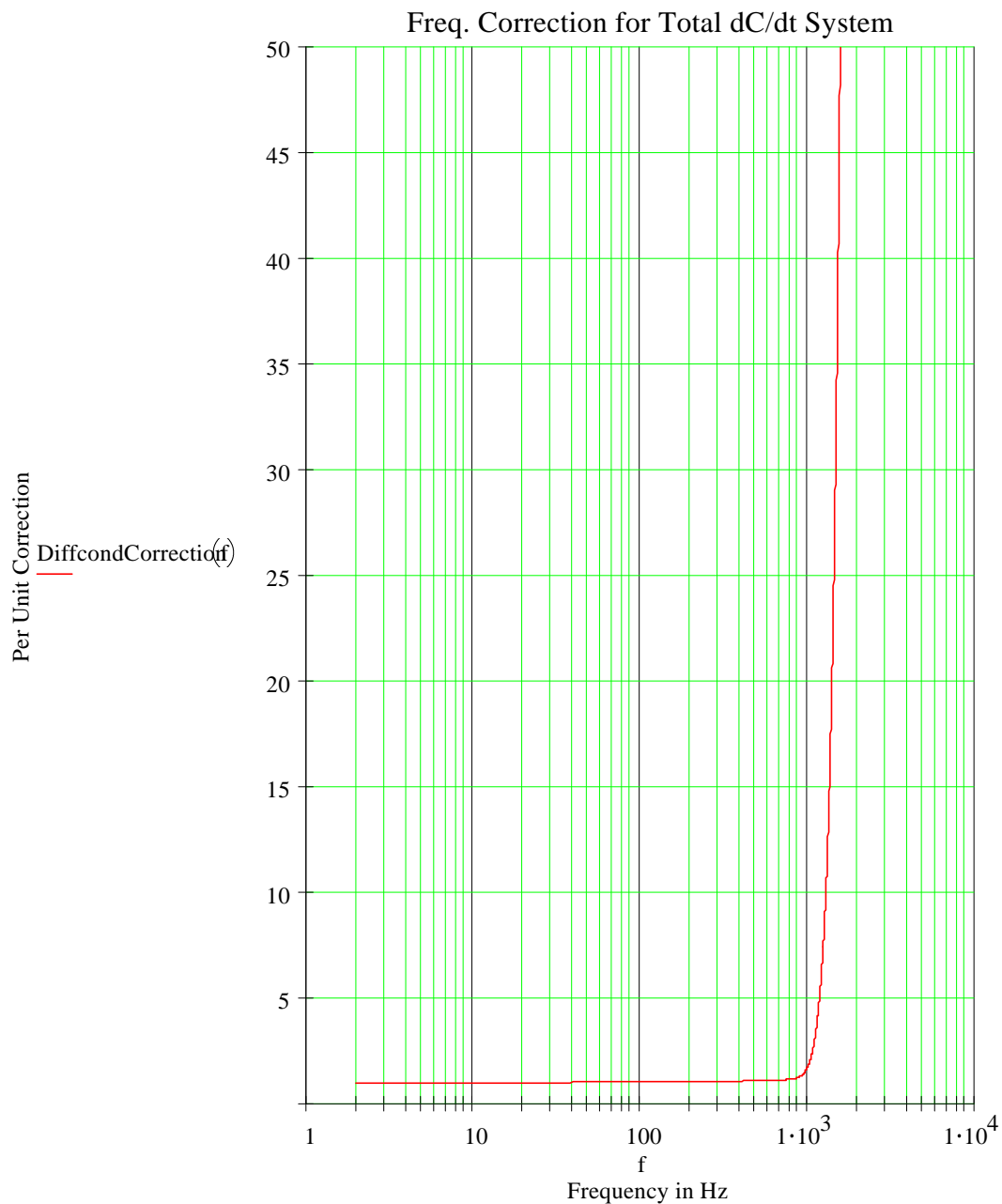

Figure M.11 Frequency Response Correction Curve for Total dC/dt System

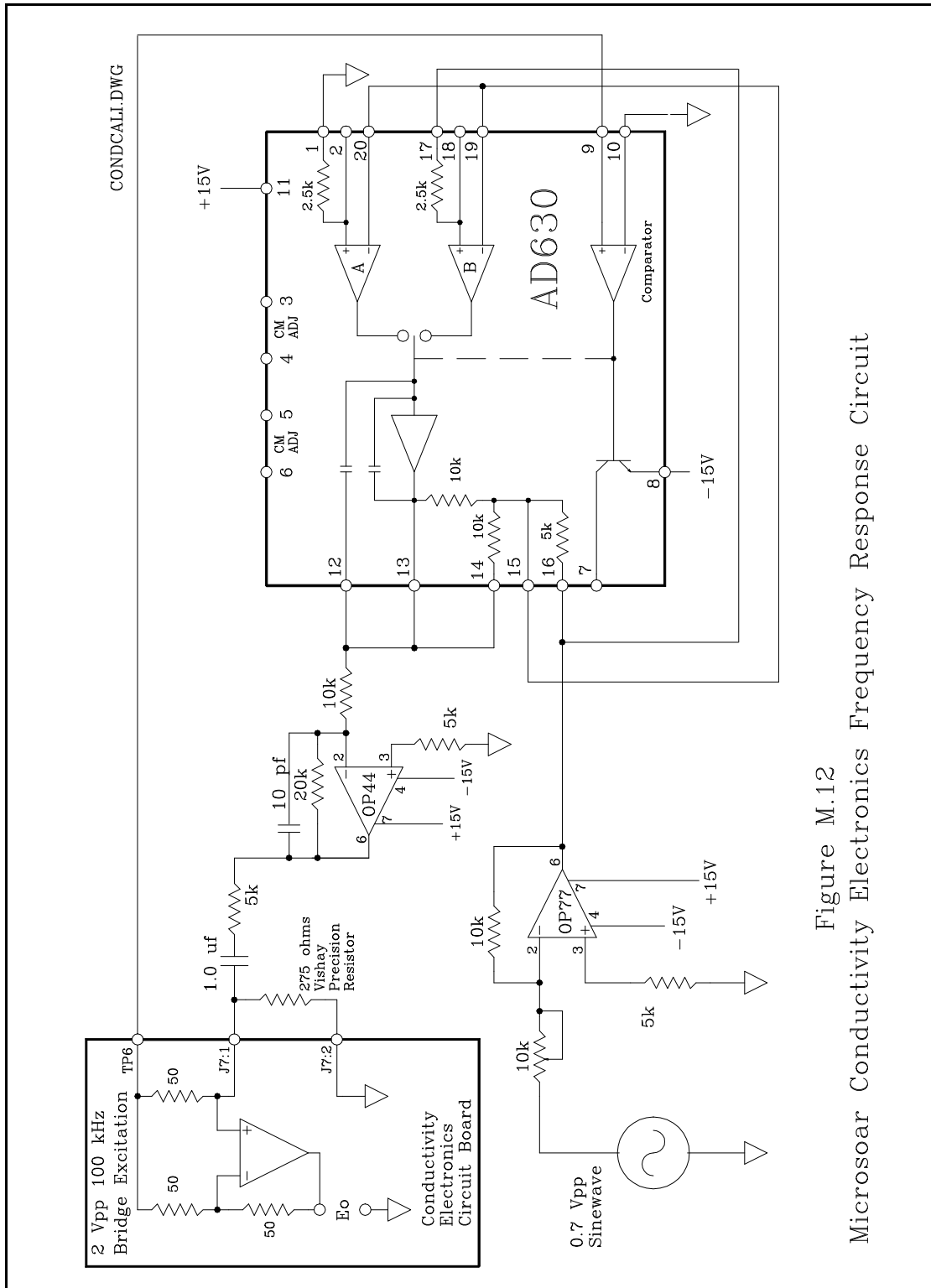

Figure M.12 Microsoar Conductivity Electronics Frequency Response Circuit

Figure M.12 MicroSoar Conductivity Electronics Frequency Response Circuit

Conductivity System Frequency Response Test Results

The circuit in Figure M.12 was built to generate test frequencies to be applied to the Conductivity Electronics Circuit Board. This circuit was connected to a Conductivity Electronics Circuit Board and the output voltage of the signal generator adjusted to 0.7 volt peak to peak. The output frequency of the signal generator was adjusted from 5 Hz to 7,000 Hz. A digital voltmeter was used to read the value of the output frequency from the signal generator and the dc voltage output from the Conductivity Electronics Circuit Board and the Filter Electronics Circuit Board. In the table below column 1 is the frequency from the signal generator, column 2 is the rms voltage at pin J7:1 of the Conductivity Electronics Circuit Board, column 3 is the dc voltage output at pin J18:1 of the Conductivity Electronics Circuit Board, column 4 is the dc voltage output at pin J17:1 of the Filter Electronic Circuit Board, column 5 is the Conductivity Electronics Circuit Board output voltage corrected to a nominal 4 volt peak to peak probe input voltage, column 6 is the Filter Electronics Circuit Board output corrected to a nominal 4 volt peak to peak probe input voltage.

Test := READPRN(condstst2)

z := 1..74

(1)	(2)	(3)	(4)	(5)	(6)
4.9	4.025	0.9755	6.83500	0.98160	6.87772
10.0	4.000	0.9770	6.84500	0.97700	6.84500
15.1	4.000	0.9776	6.84900	0.97760	6.84900
20.0	4.009	0.9776	6.84600	0.97980	6.86140
25.2	4.000	0.9778	6.85100	0.97780	6.85100
30.2	4.003	0.9787	6.85700	0.97943	6.86214
34.9	4.006	0.9791	6.86000	0.98057	6.87029
40.2	4.003	0.9787	6.85700	0.97943	6.86214
50.3	4.003	0.9785	6.85600	0.97923	6.86114
60.1	4.009	0.9800	6.86500	0.98221	6.88045
70.0	4.015	0.9813	6.87600	0.98498	6.90179
80.2	4.003	0.9788	6.85800	0.97953	6.86314
90.1	4.003	0.9792	6.85900	0.97993	6.86414
100.1	4.003	0.9790	6.85900	0.97973	6.86414
124.9	4.004	0.9796	6.86200	0.98058	6.86886
150.3	4.004	0.9798	6.86300	0.98078	6.86986

(1)	(2)	(3)	(4)	(5)	(6)
175.2	4.000	0.9789	6.86000	0.97890	6.86000
200.1	4.009	0.9804	6.86800	0.98261	6.88345
224.9	4.004	0.9788	6.85600	0.97978	6.86286
249.6	4.001	0.9782	6.85100	0.97844	6.85271
299.3	4.001	0.9774	6.84500	0.97764	6.84671
350.9	4.001	0.9770	6.84100	0.97724	6.84271
400.4	4.002	0.9764	6.83600	0.97689	6.83942
450.8	4.002	0.9759	6.83100	0.97639	6.83442
500.1	4.003	0.9752	6.82500	0.97593	6.83012
550.1	4.003	0.9743	6.82000	0.97503	6.82512
599.2	4.003	0.9735	6.81400	0.97423	6.81911
649.6	4.003	0.9729	6.80800	0.97363	6.81311
702.2	4.003	0.9717	6.79300	0.97243	6.79809
749.7	4.003	0.9708	6.76800	0.97153	6.77308
801.0	4.003	0.9703	6.70800	0.97103	6.71303
850.4	4.003	0.9691	6.55800	0.96983	6.56292
899.6	4.003	0.9682	6.25100	0.96893	6.25569
950.0	4.003	0.9666	5.66800	0.96732	5.67225
1000.1	4.002	0.9651	4.81600	0.96558	4.81841
1051.0	4.002	0.9644	3.79400	0.96488	3.79590
1102.2	4.002	0.9627	2.83200	0.96318	2.83342
1151.4	4.001	0.9612	2.07500	0.96144	2.07552
1199.8	4.000	0.9594	1.53700	0.95940	1.53700
1249.2	4.000	0.9576	1.11900	0.95760	1.11900
1300.2	4.000	0.9560	0.82100	0.95600	0.82100
1350.4	4.002	0.9548	0.60900	0.95528	0.60930
1400.0	4.002	0.9528	0.45700	0.95328	0.45723
1449.3	4.001	0.9507	0.34600	0.95094	0.34609
1501.5	4.000	0.9485	0.25900	0.94850	0.25900
1550.1	4.000	0.9466	0.19800	0.94660	0.19800
1605.0	4.001	0.9446	0.15200	0.94484	0.15204
1651.1	4.001	0.9429	0.12000	0.94314	0.12003

(1)	(2)	(3)	(4)	(5)	(6)
1702.4	4.002	0.9409	0.09440	0.94137	0.09445
1799.8	4.000	0.9361	0.06032	0.93610	0.06032
1903.8	4.001	0.9323	0.03845	0.93253	0.03846
1998.5	4.004	0.9284	0.02585	0.92933	0.02588
2093.0	4.004	0.9240	0.01782	0.92492	0.01784
2200.9	4.007	0.9194	0.01207	0.92101	0.01209
2307.5	4.009	0.9140	0.00835	0.91606	0.00837
2403.9	4.008	0.9090	0.00623	0.91082	0.00624
2496.0	4.008	0.9039	0.00482	0.90571	0.00483
2605.3	4.008	0.8980	0.00382	0.89980	0.00383
2698.1	4.009	0.8929	0.00324	0.89491	0.00325
2799.5	4.008	0.8872	0.00300	0.88897	0.00301
2809.3	4.008	0.8809	0.00278	0.88266	0.00279
2925.7	4.008	0.8799	0.00280	0.88166	0.00281
2997.6	4.009	0.8754	0.00273	0.87737	0.00274
3212.3	4.008	0.8628	0.00270	0.86453	0.00271
3494.1	4.007	0.8453	0.00250	0.84678	0.00250
3750.3	4.007	0.8293	0.00250	0.83075	0.00250
4030.7	4.006	0.8113	0.00340	0.81252	0.00341
4256.5	4.005	0.7969	0.00245	0.79790	0.00245
4495.1	4.004	0.7815	0.00251	0.78228	0.00251
4996.4	3.998	0.7490	0.00307	0.74863	0.00307
5515.0	3.999	0.7172	0.00345	0.71702	0.00345
6002.3	4.006	0.6881	0.02450	0.68913	0.02454
6505.2	4.003	0.6572	0.00260	0.65769	0.00260
7028.7	4.000	0.6222	0.00295	0.62220	0.00295

TestFreq(z) := Test_{z,1}

TestInput(z) := Test_{z,2}

TestCon(z) := Test_{z,5}

TestCondFl(z) := Test_{z,6}

Graph the normalized output of the Conductivity Electronics Circuit Board as a function of the frequency applied.

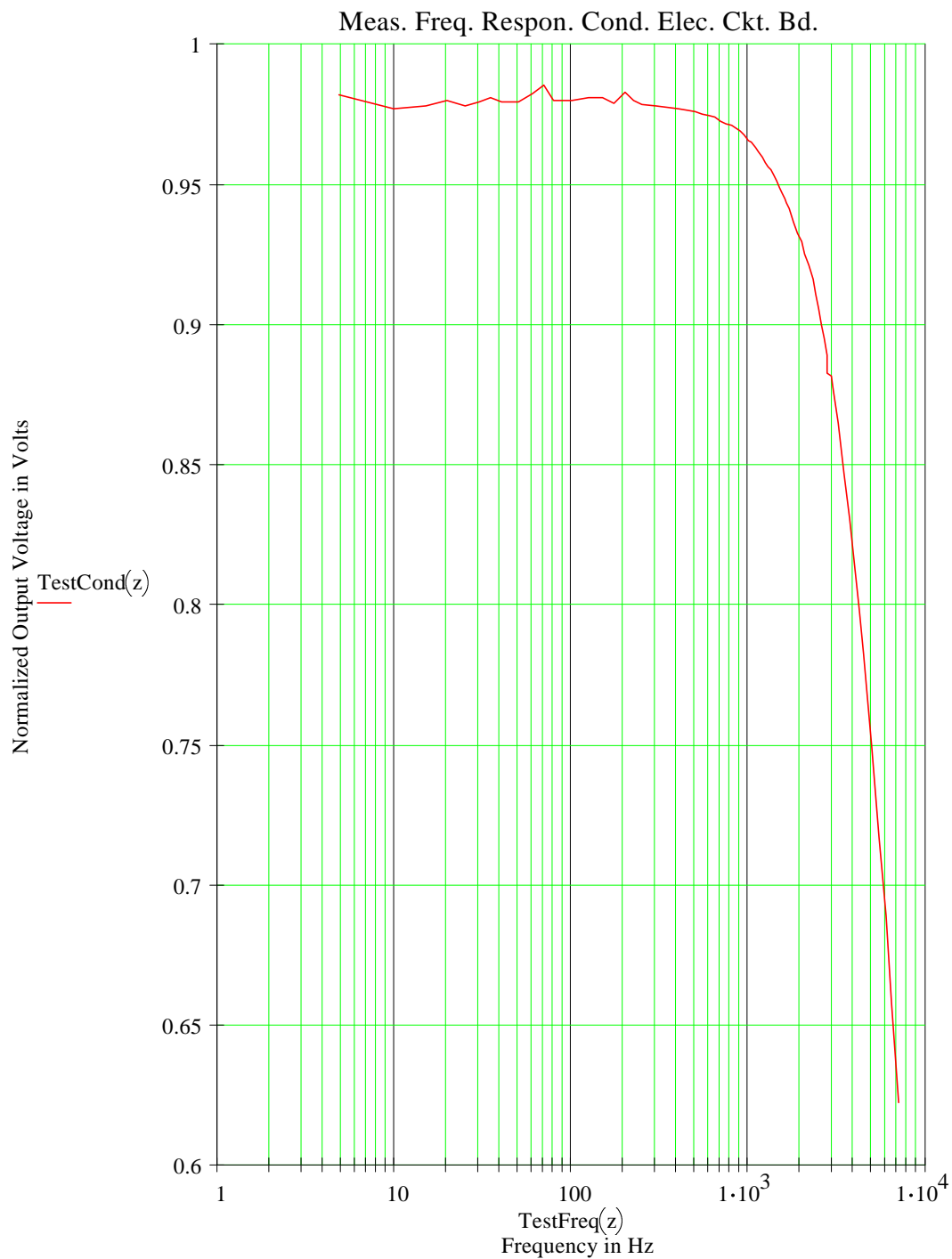

Figure M.13 Conductivity Circuit Board Measured Frequency Response, normalized output of Conductivity Electronics Circuit Board

Graph the normalized output of the Filter Electronics Circuit Board as a function of the frequency applied. This represents the frequency response of the Conductivity System

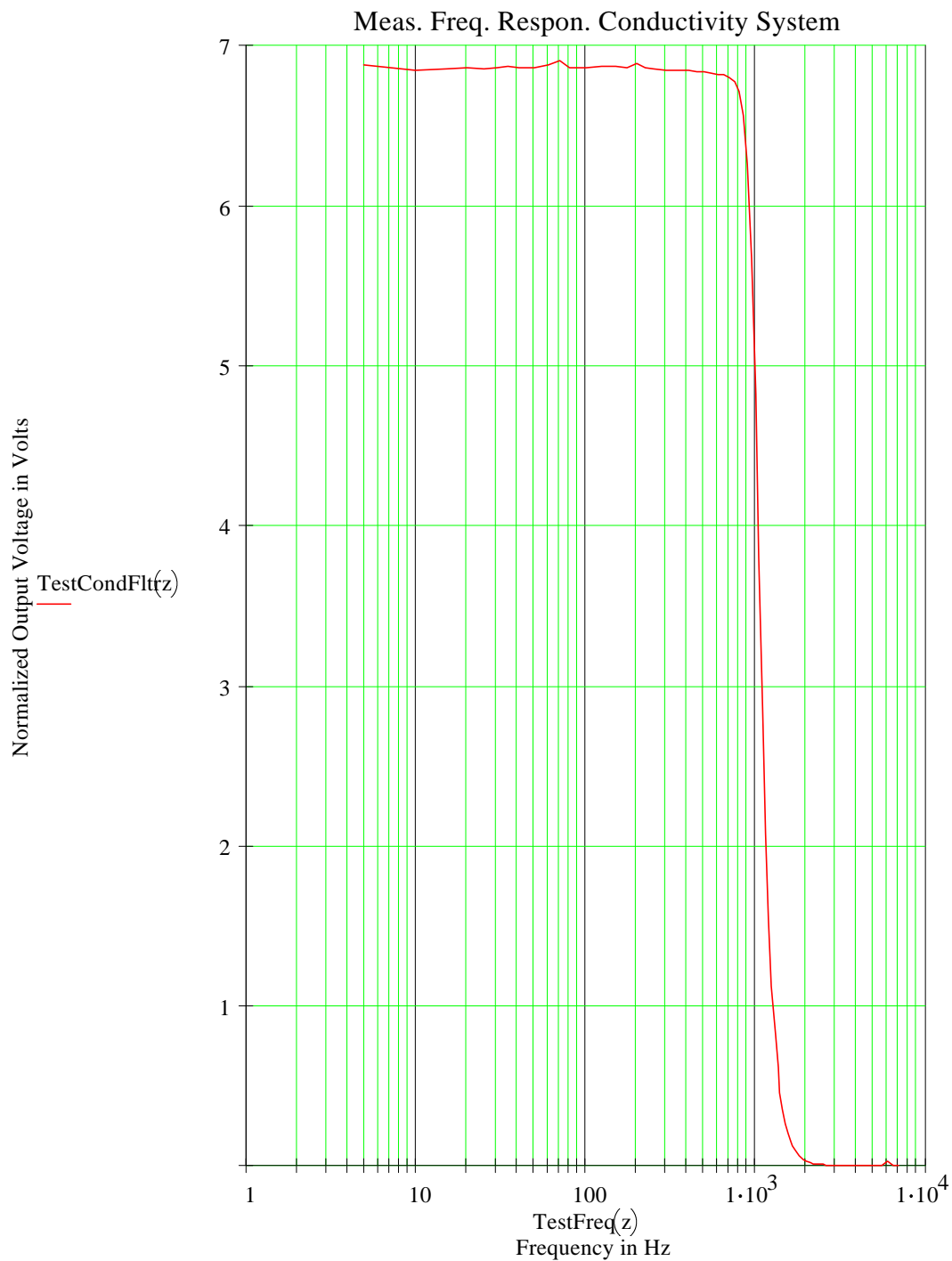

Figure M.14 Conductivity System Measured Frequency Response, normalized output of Filter Electronics Circuit Board